

ACCESSORIES AND OTHER EQUIPMENT

CAPMAX CONVEX CAP PRINTERS

CapMax cap printing system is the ultimate cap printing system. It is capable of printing from simple to the most extreme designs on the widest variety of caps, including 6 panel caps. CapMax uses a curved platen and screen that follow the natural shape of the cap. CapMax is available in four configurations. The CPMX44 comes standard with both Cap and t-shirt platens making it a dual purpose cap and t-shirt printer. CapMax bench models include CPMX11, 1 color, 1 station: CPMX21, 2 colors, 1 station: CPMX41, 4 colors, 1 station. Each includes a 110 mesh screen(s), squeegee(s), and CP2 platen(s).

Features:

- ▶ Convex screen platen system.
- ▶ Large diameter center shaft with tapered bearings.
- ▶ Sturdy tubular steel construction.
- ▶ Adjustable contact and adjustable screen angle.
- ▶ Large diameter registration points.
- ▶ Expandable with additional print heads and stations.



CPMX44 part 10202
4 colors-4 stations



CPMX11 part 10204
1 color-1 station



CPMX21 part 10203
2 colors-1 station

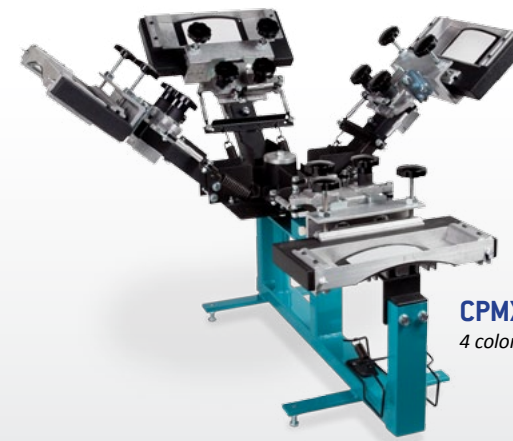

CPMX41 part 10201
4 colors-1 station

CAPMAX FLASH CURING UNITS

CapMax Flash Curing Units are a perfect match for the CapMax Printing Systems. The unique curved element design provides even and thorough flash curing on all types of caps. CapMax Flash is available as a free standing floor model or as a bench top slide model. The CapMax floor model compliments the CapMax 4 colors, 4 stations printer or manual presses outfitted with CapMax cap attachments. The CapMax Bench Model has sliding elements, perfect for CapMax bench model printers.



CAPMAX SCREENS

CapMax Screens come in a wide range of mesh counts. Choose lower mesh counts for simple, bold designs or for thicker ink deposits. Choose higher mesh counts for detailed designs, halftone designs or for thinner ink deposits.



CAPMAX PLATENS

A wide variety of quick change CapMax platens are available to provide the perfect fit for virtually every type and size of cap. CapMax printers come standard with a CP2 platen which fits twill, poplin, and nylon, caps. In addition you can get CP1 for low crown youth caps, CP3 or CP4 for summer mesh caps, or CP5 for visors. CP6 has a groove machined in the center enabling you to print right over the seam on low crown, 6-panel caps.

